

# Connect with Confidence!



INCREASES POWER  
TO THE CELL SITE  
UP TO **20 TIMES**  
OVER THE CELL  
PHONE ALONE

MADE IN  
THE USA 

## The AG SOHO 60™ and AG SOHO 65™ Adjustable-gain cellular signal boosters for the small office, home office, RV, or bus

These new adjustable-gain SOHO boosters deliver a strong cellular signal in a more confined space. Both feature higher gain than previous SOHO models, and work with any cellular device operating on any North American 800 MHz or 1900 MHz wireless network. Depending on the strength of the cellular signal outside the building, each of these boosters can provide coverage for space from the size of a single room up to an entire house.

Separate gain controls - one for the 800 MHz band, and another for the 1900 MHz band - allow the user to optimize the unit's gain in each spectrum band to match the requirements of the building in which it is installed. The adjustable gain feature also simplifies installation by making antenna placement less critical. These SOHO boosters operate wirelessly - no direct connection is required with the cellular device. They support multiple phones, air cards, and 3G tablets simultaneously, and can be paired with a variety of Wilson antennas for the perfect cellular booster system to fit your small office, home office, RV, or bus.

### Benefits

- Fewer dropped calls and lost connections
- Faster, cleaner data transfers (2G & 3G networks)
- Adjustable gain controls simplify installation
- Enjoy strong bi-directional (incoming & outgoing) signals
- Multiple devices can access the boosted signal simultaneously

 **Wilson**<sup>®</sup>  
Electronics, Inc.

[www.wilsonelectronics.com](http://www.wilsonelectronics.com)



### Install Diagram

#### Parts Included

Bi-Directional Signal Booster  
AC Power Supply

#### Outside Antenna

Recommended Wide  
Band Antenna Shown  
(Sold Separately)

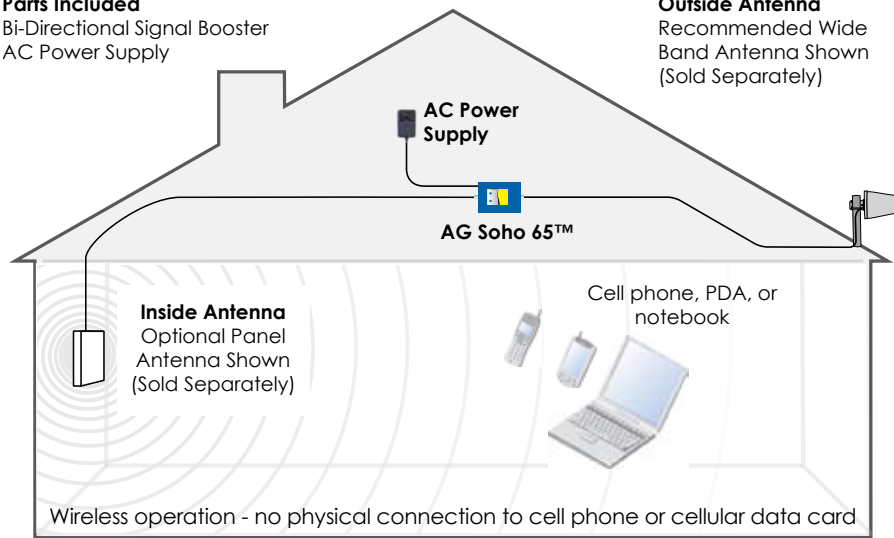

### Specifications



	AG SOHO 65	AG SOHO 60
Model Number	805045	801245
Antenna connectors	N-Female	FME-Male
Antenna impedance	50 ohms	50 ohms
Dimensions	5.7 x 4.2 x 1.5 inch (14.0 x 10.8 x 3.9 cm)	
Weight	1.27 lbs (0.544 kg)	
Frequency	824-894 MHz / 1850-1990 MHz	
Passband Gain (nominal)	800 MHz 1900 MHz	60 dB Typical, 65 dB Maximum
Power Output by Frequency	800 MHz	1900 MHz
Power output for single cell phone (uplink)	30.8 dBm	30.5 dBm
Power output for single received channel (downlink)	26.0 dBm	25.2 dBm
Noise Figure (typical downlink/uplink)	3.5 dB nominal / 6 dB nominal	
Isolation	> 90 dB	
Power Requirements	110-240 V AC, 50-60 Hz, 8 W	

### Features

- Separate adjustable gain controls for optimum signal boost
- Provides a strong, reliable signal even in weak signal areas
- Compatible with all North American 800 and 1900 MHz cellular networks
- Configurable with a variety of Wilson cellular antennas and in-line signal boosters to fit virtually any large building installation
- FCC type accepted, Industry Canada certificated

**Notes:**

1. Nominal gain is the maximum gain at any frequency in the passband.
2. Nominal bandwidth is the difference between two frequencies that are adjacent to the passband where the amplification is 20 dB lower than the passband amplification. One of the frequencies is lower than the passband and the other is higher.
3. The Manufacturer's rated output power of this equipment is for single carrier operation. For situations when multiple carrier signals are present, the rating would have to be reduced by 3.5 dB, especially where the output signal is re-radiated and can cause interference to adjacent band users. This power reduction is to be by means of input power or gain reduction and not by an attenuator at the output of the device.
4. The maximum power for 2 or more simultaneous signals will be reduced by 6 dB every time the number of signals is doubled.